

AWMA[®]

THE ORIGINAL SINCE 1972

PROFORCE[®] TOWER BAG



IMPORTANT! Read this entire manual before assembling or using this product. Retain this manual for future reference. Only use this product for its intended use. Follow all warnings concerning this product.

WARNING! This product is sold for use in HIGH RISK activities. Before using this product, read all enclosed information. You may return unused products within 14 days of purchase if you do not agree to the Terms and Conditions, which are set forth in this manual.

INTENDED USE: All PROFORCE[®] freestanding bags are intended for INDOOR USE only by trained persons or under expert supervision. This product is not designed for weapons training.

IMPORTANT

- Always place the product on a level surface.
- Keep the product away from sharp objects.
- This product is not designed for weapons training.
- Keep bystanders a safe distance from your workout area.
- Always wear bag gloves, boxing gloves, or hand wraps when using this product.
- Using this product on wood floors can cause scuff marks or scratches.
- Do not expose to freezing temperatures.
- This product is for indoor use only.
- Take caution when assembling, disassembling, using, and moving the Product.

For more information, please visit www.AWMA.com

TERMS AND CONDITIONS

THE FOLLOWING TERMS AND CONDITIONS APPLY TO ALL SALES AND USES FOR EQUIPMENT OR PRODUCTS SOLD BY ASIAN WORLD OF MARTIAL ARTS ("AWMA") (WHETHER SOLD THROUGH AWMA'S WEBSITE, CATALOG, OR OTHERWISE) (THE "PRODUCT(S)"). PLEASE REVIEW CAREFULLY. THESE TERMS AND CONDITIONS INCLUDE LIMITED WARRANTIES, AND DISCLAIMERS OF LIABILITY AND ARBITRATION PROVISIONS. KEEPING, USING, OR ALLOWING USE OF ANY PRODUCT INDICATES YOUR AGREEMENT TO THESE TERMS. IF YOU DO NOT WISH TO AGREE TO THESE TERMS, YOU HAVE 14 DAYS FROM DATE OF PURCHASE TO RETURN THE UNUSED PRODUCT.

DUTY OF COACHES, TRAINERS, GYMS, AND OTHER PURCHASERS TO INFORM OTHERS OF THESE TERMS AND CONDITIONS

Before you allow others to use an AWMA product, you agree that (a) you will require that they (or their legal guardian if they are minors) read, understand, and agree to these Terms and Conditions of Sale or Use, (b) you believe they (or their guardian) understand that they are participating in a high-risk activity and assume the risk of death, paralysis, or other personal injury, and (c) you agree to indemnify, defend, and hold AWMA harmless from any claims made by them arising from their use of any Product.

HIGH RISK ACTIVITY

Products sold by AWMA include equipment and gear used in boxing, martial arts, mixed martial arts, yoga, fitness, weight training, kick-boxing, competitions and/or demonstration (collectively, "Martial Arts"). Participation in Martial Arts is a high-risk sports activity. Participation in Martial Arts may result in injury, sometimes severe, including, but not limited to, disability, paralysis, or death. You participate in any of these activities at your own risk. You agree to consult with your personal physician before participating in any of these high-risk activities. You, and whoever uses the Products sold by AWMA, use the Products at Your own risk. Read, understand, and follow specific warnings and instructions on Products and in product literature or inserts before using the Products. Save these documents for reference.

ASSUMPTION OF THE RISK

Participation in Martial Arts should be considered a high-risk activity. Your participation in Martial Arts is at your own risk. You agree to consult with your personal physician before participating in any of these high-risk activities. By buying or using any of the Products, You understand and agree that Martial Arts are high risk activities and, to the extent permitted by law, **YOU EXPRESSLY AND VOLUNTARILY ASSUME THE RISK OF DEATH, PARALYSIS OR OTHER PERSONAL INJURY TO YOU OR OTHERS SUSTAINED WHILE PARTICIPATING IN SUCH ACTIVITIES OR USING THE PRODUCTS WHETHER OR NOT SUCH HARM WAS CAUSED BY THE NEGLIGENCE OR OTHER FAULT OF AWMA**, including, but not limited to, **Product** defect or malfunction from whatever cause, or any other fault of AWMA. Additionally, you agree to indemnify, defend and hold AWMA harmless from any third party claims arising from such high risk activities, Martial Arts, Martial Arts Weapons or any other Product. Purchasers, users and participants assume all risk of injury. AWMA cannot and will not be responsible for harm caused by any use or misuse (whether proper or not, authorized or not) of Products.

USE OF THE PRODUCTS

The Products might provide varying degrees of protection, but they are not warranted to protect the user from or prevent any injury, paralysis or death. Users are responsible for their choice and use of the Products purchased. Users of these Products can be subject to injuries, including, but not limited to, physical injury, paralysis, or death, despite using the Products as intended. The user must assume full responsibility for all risk of injuries. The

manufacturer and distributor assume no liability for injuries, paralysis or death suffered while wearing or using the Products.

READ AND FOLLOW SPECIFIC WARNINGS AND INSTRUCTIONS ON PRODUCTS AND IN PRODUCT LITERATURE OR INSERTS. SAVE THESE DOCUMENTS FOR REFERENCE. Because Products wear down through use and over time, **ALWAYS INSPECT ALL** Products, including, but not limited to, any gear (training or otherwise), weapons, equipment, mats, and any protective gear *before* each use. Products that show wear should be immediately replaced and not used in any Martial Arts activity. **Do not use old, damaged, or modified Products of any kind. Use of Products MUST be under the supervision of a skilled instructor who responsibly monitors techniques and intensity of training to assure that students or users are properly trained and physically conditioned. Minors using these Products should have constant, qualified, adult supervision.** AWMA products do not eliminate, warrant, or guarantee to protect the user from death, disability, or personal injury.

WARRANTY DISCLAIMER

THE ABOVE STATED WARRANTIES ARE IN LIEU OF ALL OTHER WARRANTIES EXPRESSED OR IMPLIED INCLUDING THE WARRANTIES OF MERCHANTABILITY AND FITNESS FOR A PARTICULAR PURPOSE AND OF ALL OTHER OBLIGATIONS AND LIABILITIES OF AWMA. AWMA NEITHER ASSUMES, NOR AUTHORIZES ANY OTHER PERSON TO ASSUME FOR IT, ANY OTHER LIABILITY IN CONNECTION WITH THE SALE OF PRODUCTS FROM ITS WEBSITE, CATALOG OR OTHERWISE. THE ABOVE LIMITED WARRANTIES SHALL NOT APPLY TO ANY PRODUCT WHICH HAS BEEN SUBJECT TO ACCIDENT, NEGLIGENCE, ALTERATION, ABUSE, OR MISUSE, THE TERM "ORIGINAL PURCHASER" AS USED IN THIS WARRANTY MEANS THE PERSON TO WHOM THE PRODUCT IS ORIGINALLY SOLD AS SHOWN ON THE SALES INVOICE. THESE WARRANTIES SHALL APPLY ONLY WITHIN THE BOUNDARIES OF THE UNITED STATES AND CANADA.

LIMITATION OF LIABILITY

As set forth above under the limited warranty provisions, AWMA liability is limited to repair or replacement of its products which are returned to it prepaid in the specified period of time. In no event shall AWMA's liability exceed the value of the products sold. AWMA shall not be liable for any special or consequential damages that result from the use of any product sold through this website or through its catalog. Applicable law may not allow the limitation or exclusion of liability of special or consequential damages so the above limitation or exclusion may not apply to your purchase, but it is intended to be the maximum limitation as permitted by law.

GENERAL DISCLAIMER

Product descriptions, typographic, pricing and photographic errors are unintentional and subject to correction. We regret, but are not liable for such errors. AWMA reserves the right to reject any orders placed for a product listed at an incorrect price. If you discover an error in our website or catalog, please let us know. Product weights are approximate and are measured on an averaged ounce per square yard basis. Actual product weights may vary based on various factors, including, but not limited to, the color of the product. AWMA makes no express guarantees or warranties of any kind with respect to actual product weights. All prices, specifications, and color shades are subject to change without notice.

SEVERABILITY

If any portion of these terms and conditions is invalidated by a Court of competent jurisdiction, then all of the remaining terms and conditions shall remain in full force and effect.

OVERVIEW CHART

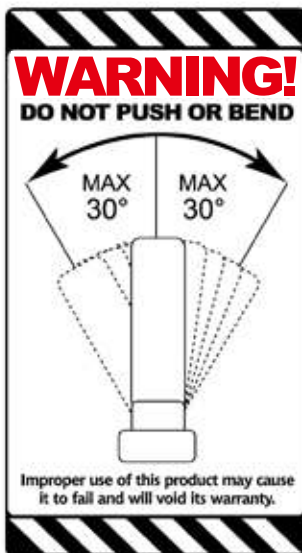
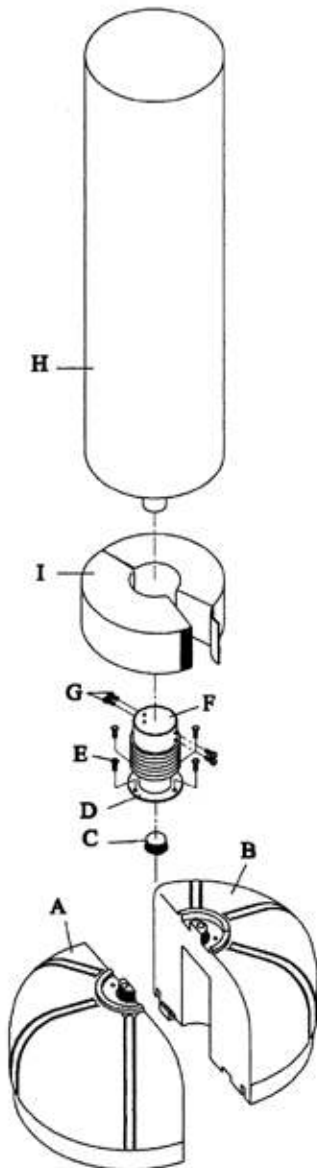

PROFORCE® TOWER BAG AND ASSEMBLY INSTRUCTIONS

- STEP 1.** Open Cap (C) on the Base (A) and Base (B) fills the Base (A) and Base (B) with Water or Sand as shown in **Figure B**. Fix the Base (A) and Base (B). Then close the Cap (C) tight as shown in **Figure A**.
- STEP 2.** Attach the Bottom Bracket (D) to the top of the Flex-Coil (F) to the top of the Base (A) with four Screws (E).
- STEP 3.** Fix the Tower Bag (H) with four Screws (G) tighten as shown in **Overview Chart**.
- STEP 4.** Slide the Foam (I) over the Flex-Coil (F) as shown in **Overview Chart**.

Always place the Tower Bag on a level surface. This bag is not designed for weapons training. Always wear bag gloves, boxing gloves, or hand wraps when using this product. Using this product on wood floors can cause scuff marks or scratches. The Tower Bag is designed for indoor training, such as, kicks, punches and individual fitness workouts by trained people or under expert supervision.

FIGURE A

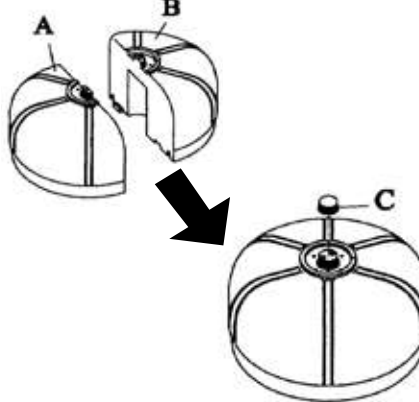
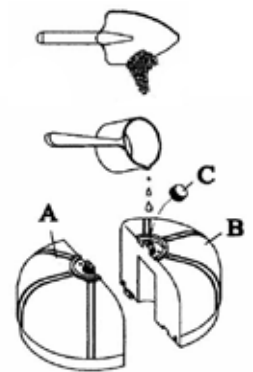

FIGURE B



Use a two wheeled cart/hand truck/dollie to move product.